

**Physics 200 (Stapleton)
Midterm Review Packet**

- Topics/concepts will be the same as those tested by the unit tests. While the concepts, formulas, etc. will be the same as those tested on the unit tests, do not expect any of the questions or problems to be exactly the same as those on any unit test. As you study, make sure that you fully understand all of the concepts relating to the unit test questions and problems. Do not just memorize answers. To reduce your work time, some of the problems that included friction on the unit tests will not include friction on the midterm. Be prepared to solve problems without friction.
- Format and Distribution of Material: 100 points total -- 25 Multiple choice (1 point each); 15 Problems (5 points each)
 - 1-D Kinematics: 5MC, 3 Problems
 - 2-D Kinematics: 6MC, 3 Problems
 - Newton's Laws (1-D): 6MC, 3 Problems
 - Newton's Laws (2-D): 1 Problem
 - Gravity and Circular Motion: 4MC, 3 Problems
 - Work and Energy: 4MC, 2 Problems
- The formulas below (and G) will be provided. Opting out of the formulas (and G) will earn you an extra 4%.

Provided Formulas:

$$\bar{v} = \frac{\Delta x}{\Delta t} \quad \bar{v} = \frac{v + v_0}{2} \quad v = v_0 + at \quad a = \frac{\Delta v}{\Delta t}$$

$$\Delta x = v_0 t + \frac{1}{2} at^2 \quad \Sigma F = ma \quad \Sigma F = \text{Vector sum of forces}$$

$$W = mg \quad F_{fr} = \mu F_N$$

$$a_{\text{uniform circle}} = \frac{v^2}{r} \quad \Sigma F_{\text{uniform circle}} = \frac{mv^2}{r}$$

$$F_{\text{gravity}} = G \frac{Mm}{r^2} \quad G = 6.67 \times 10^{-11} \frac{\text{Nm}^2}{\text{kg}^2}$$

$$\frac{T_A^2}{T_B^2} = \frac{r_A^3}{r_B^3} \quad W = Fd \quad P = \frac{W}{t} \quad W_{\text{net}} = \Delta KE$$

$$KE = \frac{1}{2} mv^2 \quad PE_{\text{grav}} = mgh \quad PE_{\text{spring}} = \frac{1}{2} kx^2$$

$$F_{\text{spring}} = -kx \quad KE_i + PE_i + W_{\text{nc}} = KE_f + PE_f$$

Not always present can be grav, spring, or both

Not Provided, but helpful to know or be able to derive:

$$g = \frac{GM}{r^2} \quad v = \sqrt{\frac{GM}{r}}$$

1-D Kinematics

Part I (Conceptual and Multiple Choice):

1. Describe an example of motion that has negative acceleration and negative velocity.
2. Describe an example of motion that has positive velocity and negative acceleration.
3. Which one of the following situations is impossible?
 - A) A body having a positive velocity and a negative acceleration
 - B) A body having a negative velocity and a negative acceleration
 - C) A body having zero velocity and negative acceleration
 - D) A body having constant velocity and positive acceleration
4. In which of the following situations is it possible for an object to be accelerating?
 - a. Velocity is positive and constant
 - b. Velocity is negative and constant
 - c. Speed is positive and constant
 - d. Speed is negative and constant
5. If speed is increasing, which of the following must always be true?

A) Acceleration is zero	B) Velocity is increasing
C) Acceleration is positive	D) both A and B
E) A, B, and C	F) none of these

6. Which **velocity** graph represents the same motion as position graph C?

E F G H

7. Which **acceleration** graph represents the same motion as position graph D?

I J K

8. Which **velocity** graph represents the same motion as acceleration graph K?

E F G H

9. Which **position** graph represents the same motion as acceleration graph I?

A B C D

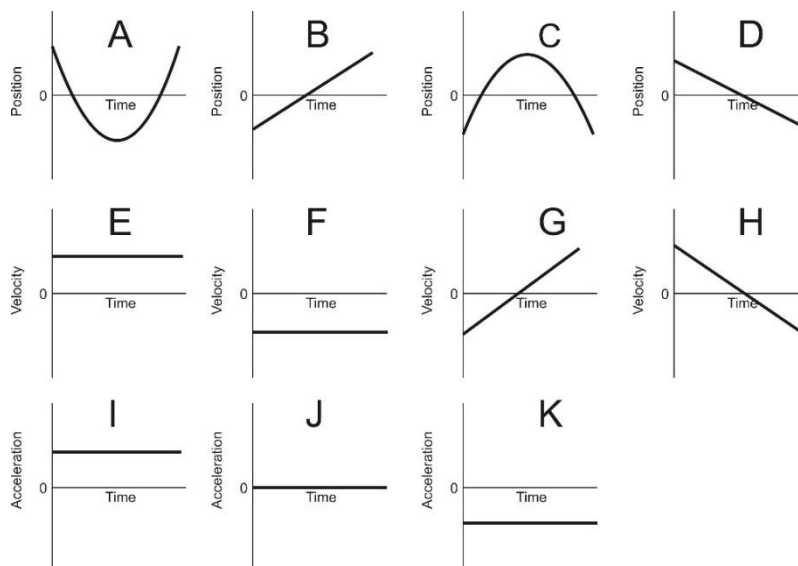

- 10-13. A car travels forward 8m to the right (positive direction). Then it drives in reverse, traveling leftward for 16m. Assuming that the entire round trip takes 8 seconds...

10. What is the average speed for this round trip?

a. 1m/s b. 2m/s c. 3m/s d. -1m/s e. -2m/s f. -3m/s

11. What is the average velocity for this round trip?

a. 1m/s b. 2m/s c. 3m/s d. -1m/s e. -2m/s f. -3m/s

12. What is the total distance traveled by the car on its round trip?

a. 8m b. 16m c. 24m d. -8m e. -16m f. -24m

13. What is the displacement for this round trip?

a. 8m b. 16m c. 24m d. -8m e. -16m f. -24m

14. Which letter choice correctly describes the speed, acceleration, and velocity of an object that is falling in the absence of air resistance? +, -, and = mean "increase, decrease, and no change," respectively.

Choices	Speed	Velocity	acceleration
A	+	-	+
B	+	+	-
C	-	-	=
D	-	+	=
E	+	-	=

15. Suppose a ball is thrown straight upward. What are the values of the ball's velocity and the acceleration when it reaches its highest point?

Velocity = _____ Acceleration = _____

16. A typical elevator waits for a passenger on the 2nd floor of a hotel. The elevator then travels from the second floor to the 1st floor. Then the elevator remains on the first floor. On the graph below, sketch the changes in the elevator's **acceleration** over this 30 second period. Correct answers may vary somewhat, depending on your assumptions.

Time	Event
0s	Elevator is waiting motionless on 2 nd Floor.
10s	Elevator begins traveling to 1 st floor.
20s	Elevator comes to rest (stops) at the 1 st floor.
30s	Elevator is still waiting on 1 st floor.

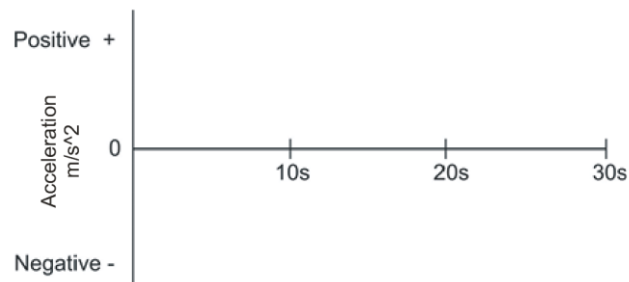

Problems [4 points per problem – including correct units] *In the case of wrong answers, partial credit may be given for correct formulas – in their original form -- and correct units. Enclose your answers and your starting formulas in boxes.*

- How long does it take a racehorse to travel a distance of 300m if it is running at a constant speed of 19m/s?
- A car traveling at a rate of 25m/s decelerates at a rate of -2m/s^2 in order to avoid hitting another car. If this deceleration lasts for 3 seconds, what is the velocity of the decelerating car at the end of those 3 seconds?
- A grape is shot directly upward in the absence of air resistance. After 12 seconds of flight, the grape returns to the same elevation from which it was launched. How high above the launch point did the grape travel?
- A circus performer plans to jump from a high platform into shallow pool of water, entering the water with a velocity of -15m/s . If the diver is willing to risk a maximum acceleration no greater than 120m/s^2 , what is the minimum distance (water depth) over which the performer must slow down and stop?

2-D Kinematics

Note about Partial Credit on Problems: *In the case of wrong answers, partial credit may be given for correct formulas – in their original form -- and correct units. Enclose your answers and your starting formulas in boxes.* For problems with multiple parts, if you do not know the answer to one part, you may make up an answer to use in a subsequent part. For river problems, you may receive partial credit for head-to-tail vector diagrams properly identifying the resultant and component vectors. Attach extra paper if necessary.

Part 1: Short Answer and Multiple Choice: (11 points total)

The diagram on the right shows a projectile that is launched from left to right in the absence of air resistance.

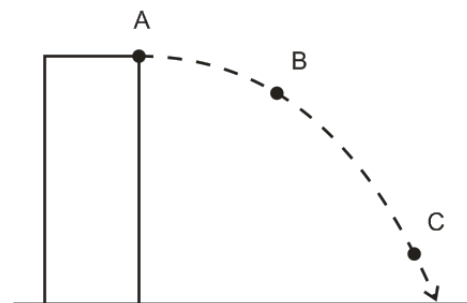

1. $1\text{m/s} = \underline{\hspace{2cm}}$ mph
- 2-4. (4 points, total)
 - For each lettered location on the right, draw labeled arrows representing the object's speed (v), x velocity (v_x), and y velocity (v_y).
 - If v , v_x , or v_y is equal to zero at any point, do not draw an arrow.
 - If, at any point, two or more vectors are identical, you may draw one arrow with multiple labels.
 - The lengths of your arrows must be in correct proportion to one another.
 - The directions of your arrows must be correct.

Multiple Choice: Circle the correct answer.



5. Two of the vectors on the right are components that may be added together to produce the third (resultant) vector. Circle the resultant.
6. A projectile is shot vertically upward with a given initial velocity. It reaches a maximum height of 50.0 m. If, on a second shot, the initial velocity is doubled (i.e. $2X$), then the projectile will reach a maximum height of:
 A) 75 m B) 100 m C) 150 m D) 200 m E) 450 m
7. If θ is the angle of vector A with respect to the $+x$ -axis, the y -component of the vector with magnitude A is given by
 A) $A \cos \theta$ B) $\mu A \cos \theta$ C) $A \sin \theta$ D) $mg - A \sin \theta$ E) $\tan^{-1}\theta$
8. A vector in the xy plane has an x -component of $+5.7$ and a y -component of $+9.4$. The angle it makes with the positive x axis is approximately:
 A) 26° B) 34° C) 45° D) 59° E) 66°

- 9-10. A rock is thrown from the edge of a cliff with an initial velocity v_0 at an angle θ with the horizontal as shown above. Point P is the highest point in the rock's trajectory and point Q is level with the starting point. Assume air resistance is negligible.

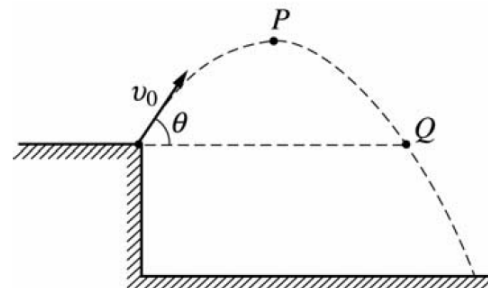

9. Which of the following correctly describes the horizontal and vertical speeds and the acceleration of the rock at Point P?

<u>Acceleration</u>	<u>Horizontal Speed</u>	<u>Vertical Speed</u>	
A)	0	$v_0 \cos \theta$	-g
B)	$v_0 \cos \theta$	0	0
C)	$v_0 \cos \theta$	$v_0 \sin \theta$	-g
D)	0	0	-g
E)	$v_0 \cos \theta$	0	-g

10. (see diagram from #9) Which of the following correctly describes the horizontal and vertical speeds and the acceleration of the rock at Point Q?

	<u>Horizontal Speed</u>	<u>Vertical Speed</u>	<u>Acceleration</u>
A)	0	$v_0 \cos \theta$	-g
B)	$v_0 \cos \theta$	0	0
C)	$v_0 \cos \theta$	$v_0 \sin \theta$	-g
D)	0	0	-g
E)	$v_0 \cos \theta$	0	-g

Part II: "River Problems" (14 points)

1. (8 Points) An aircraft carrier is traveling at a rate of 10m/s southward. An airman drives a golf cart uses a compass to head eastward across the moving carrier, perpendicular to the carrier's length. The golf cart's speedometer reads 6m/s.
- What is the actual speed of the golf cart, relative to the Earth?
 - What is the golf cart's direction of travel? Describe the direction in degrees relative to North, South, East, or West.



Part III: Projectile Problems (24 points)

3. (8pts) You shoot a projectile horizontally from a 1m high table top. The projectile flies 12m horizontally before it hits the floor.
- How long was the projectile in the air?
 - What was the projectile's initial speed as it left the table top?
4. (8 points) An athlete executing a long jump leaves the ground at a 28.0° angle above horizontal and with an initial speed of 8m/s. His landing point is at the same elevation as his take-off point. Determine the following.
- What was his total time aloft?
 - What horizontal distance did he travel?

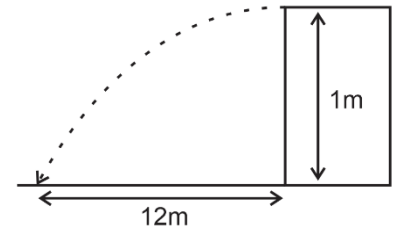

Newton's Laws, 1-D

- A car is traveling forward on a level surface. Suddenly the driver steers the car leftward. Which of the following best describes the new force that pushes the car leftward?
 - Road friction pushing the tires
 - Driver pushing the steering wheel
 - Car exhaust pushing the car
 - Engine force pushing the drive shaft
 - Steering wheel pushing the tires
- A stone is thrown directly upward into real air (including air resistance). It goes up; it comes down. At what point in the stone's flight is it truly in "free-fall?" In other words, when is it experiencing only one force – gravity?
 - On the way up
 - On the way down
 - At the top
 - The whole time
 - Never

3. A stone is thrown directly upward into real air (including air resistance). It goes up; it comes down. After the initial throw, when does the speed of the stone change at the fastest rate?
 - a. On the way up
 - b. On the way down
 - c. At the top
 - d. Speed changes at the same rate the whole time.
4. Some steel cars and some rubber cars crash into some brick walls and some straw walls. In which collision is the force applied to the wall greater than the force applied to the car?
 - a. Steel car, brick wall
 - b. Steel car, straw wall
 - c. Rubber car, brick wall
 - d. Rubber car, straw wall
 - e. Never. The forces are always equal.
5. As an astronaut travels from the international space station to the Earth, what happens to her mass and weight?
 - a. Mass increases, weight stays the same.
 - b. Weight increases, mass stays the same.
 - c. Both mass and weight increase.
 - d. Both mass and weight stay the same.
6. Assuming that two falling objects experience the same force of drag, which of the following must be true?
 - a. They must take the same amount of time to fall.
 - b. They must have the same terminal velocity.
 - c. They must have the same weight.
 - d. They must have the same shape.
 - e. None of these answers must be true.
7. 20kg Sally is using a massless rope to drag her 0.2kg stuffed owl. Sally, the owl, and the rope are accelerating together at a rate of 1m/s^2 . In this case,
 - a. The rope exerts a stronger force on Sally than it does on the owl.
 - b. The rope exerts a stronger force on the owl than it does on Sally.
 - c. The rope exerts equally strong forces on Sally and the owl.
 - d. The rope does not exert force on either Sally or the owl.
9. An object of mass m is hanging by a string from the ceiling of an elevator. The elevator is moving with constant upward acceleration. What is the tension in the string?
 - a. less than mg
 - b. exactly mg
 - c. greater than mg



Short Answer:

1. The water rocket in the diagram on the right currently has a mass of **0.24kg**, and it is accelerating upward at a rate of $1,000\text{m/s}^2$. The force of thrust provided by the water pushing the rocket upward is $F_{\text{thrust}} = 248\text{N}$. On the diagram, draw **all** of the **individual** forces that are acting on the rocket. Use arrows to show the direction of each force. Label each arrow with an appropriate **name** of the force, the **correct magnitude of the force**, and the **correct units**. [Assume that there is air resistance.]
3. A **1kg** brick is dropped from a helicopter. The brick falls until it reaches terminal velocity, and then it hits the ground. The table below provides incomplete descriptions of four moments during the brick's descent (labeled A-D). They are intentionally scrambled so that they are not in order! Use the second column to correctly order the moments in time. Also enter the correct drag force and net force for each of the moments.

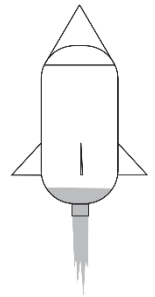

Moments in the descent	Order (1=occurs first, 3 = occurs last)	Brick Weight [Not Graded]	Force of Drag on brick	Net Force acting on brick	Brick Acceleration
A					0m/s^2
B					-9.8m/s^2
C					-4m/s^2

Problems:

1. A student has a mass of 40kg.
 - a. What is her weight on Earth?
 - b. On a different planet the same student has a weight of 1,200N. What is the acceleration due to gravity on that planet?
2. Klem has a 2kg block of wood.
 - a. How fast does Klem's block of wood accelerate when there is a **net force** of 20N acting on the block?
 - b. Klem's 2kg block of wood is at rest. If the block has a coefficient of static friction (μ_s) of 0.4, how much force does he have to apply in to the resting block in order to start it moving?
 - c. Klem's block of wood has a coefficient kinetic friction (μ_k) equal to 0.3. If Klem keeps pushing the block with the same force that you calculated in part B, how fast will the block accelerate?
 - d. Suppose Klem accelerates the block of wood until its velocity is 1m/s. If he then wants to maintain a constant 1m/s velocity, how much force must he apply to the block? (Keep using $\mu_k=0.3$)
3. A student is standing on a bathroom scale in an elevator, and the scale currently reads 500N. The elevator is accelerating upward at a rate of 2m/s^2 . What is the student's mass?

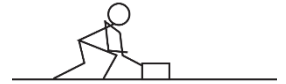

5. The diagram on the right shows three masses connected by frictionless, massless strings passing over frictionless pulleys. The surface that is in contact with the 10kg mass has a $\mu_k = 0.6$. The masses and strings are in motion.

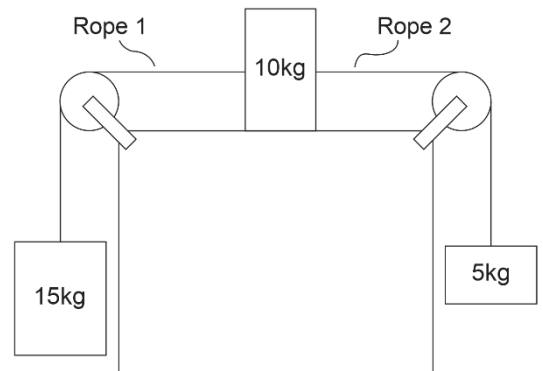

- a. Find the acceleration of the entire system of masses and ropes.
- b. Find the tension in Rope 1
- c. Find tension in Rope 2.

Newton's Laws in 2-D

For each problem, enter the missing information into the table.

1. Two segments of rope are supporting an object. Segments are angled at the same angle, relative to horizontal.

Description	Magnitude	Units	Direction
Angle	55	degrees	below horizontal
Mass of object	20	kg	NA
Weight of hanging object			
Vertical component of tension in the left string			
Tension of left string			

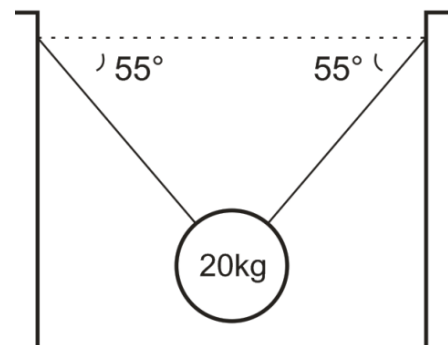

2. A sliding mass on an incline is connected via a string and pulley to a hanging mass. μ_k is given.

Description	Magnitude	Units	Direction
Angle of incline to horizontal	20	degrees	Above leftward
Sliding mass	20	kg	NA
Hanging mass	15	kg	NA
Coefficient of friction	0.3	NA	NA
Weight of sliding mass			
Perpendicular Component of sliding object weight			
Parallel Component of sliding object weight			
Weight of hanging object			
Normal Force acting on sliding object			
Friction			
Net Force			
Acceleration			
String Tension			

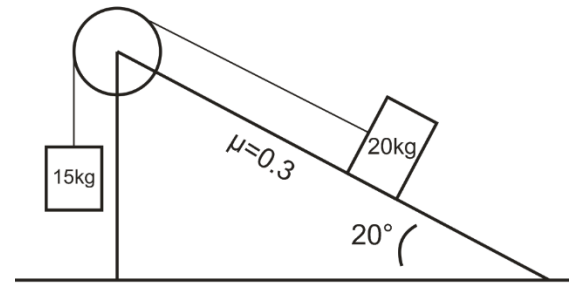

Gravity and Circles

I. Multiple Choice (1pt each)

- A tennis ball is swung in a vertical circle (horizontal axis) at a constant velocity. Where in the swing is the tension in the string the weakest?
 - At the bottom of the swing
 - At the top of the swing
 - Half-way between the top and the bottom, on the way up
 - Half-way between the top and the bottom, on the way down
- If car goes around a curve of radius r at a constant speed v , the car's acceleration is...
 - directed towards the curve's center.
 - directed away from the curve's center.
 - directed toward the back of the car.
 - directed toward the front of the car.
 - zero.
- A ball of mass m attached to a string is moving in a horizontal circle of radius r with a uniform speed of v . The tension in the string (i.e. the force needed to keep the ball moving in a circle) is F_T . If the velocity of the ball triples to $3v$ (i.e. 3 times its original velocity), what is the new tension in the string?

A. $F_T/9$ B. $F_T/3$ C. F_T D. $3F_T$ E. $9F_T$

4. A ball of mass M attached to a string is moving in a horizontal circle of radius r with a uniform speed of v . The tension in the string (i.e. the force needed to keep the ball moving in a circle) is F_T . If the mass of the ball increases to $5M$ (i.e. 5 times its original mass), what is the new tension in the string?
 A. $F_T/25$ B. $F_T/5$ C. F_T D. $5F_T$ E. $25F_T$
5. Which is not one of Kepler's 3 Laws?
 A. Planets orbit the Sun in ellipses
 B. An imaginary segment drawn between the Sun and the planet sweeps out equal areas in equal times
 C. A planet's centripetal acceleration is proportional to its velocity squared.
 D. The square of a planet's period is proportional to the cube of its orbital radius
7. The speed of a comet, while traveling in its elliptical orbit around the Sun,
 A. is constant.
 B. slows to zero at its furthest distance from the Sun.
 C. increases as it nears the Sun.
 D. decreases as it nears the Sun.
8. The gravitational force between two masses separated by a distance r is 400 N. If the distance between the two masses (measured from center to the center) is now cut in half, the gravitational forces becomes
 A. 1600 N B. 800 N C. 400 N D. 200 N E. 100 N
9. The table below presents four planets whose masses and radii are expressed in terms of Earth's mass (M_E) and Earth's radius (R_E). On each planet, a ball of a different mass is dropped from a height of 10m. Neglecting air resistance, in which case will the ball fall fastest?

	Mass of Planet (Earth masses)	Radius of Planet (Earth radii)	Ball Mass (kg)
A.	$1 M_E$	$1 R_E$	1kg
B.	$4 M_E$	$2 R_E$	6kg
C.	$5 M_E$	$1 R_E$	8kg
D.	$2 M_E$	$0.5 R_E$	2kg

10. A car of mass m

is traveling at a constant speed through a circular loop-the-loop of radius r . What normal force does the car experience at the top of the loop? [assume down = negative]

- a. mv^2/r b. mg c. $mv^2/r - mg$ d. 0 e. $-mg - F_N$
11. In order to properly simulate Earth's gravity, approximately how fast must the outer edge of a cylindrical space station rotate, if the radius of the space station is 5 m?
 a. 1m/s b. 3m/sc. 5m/s d. 7m/se. 9m/s

12-13. The ellipse on the right represents the path of an orbiting planet. The small black dots represent perihelion (closest to the Sun) and aphelion (farthest).

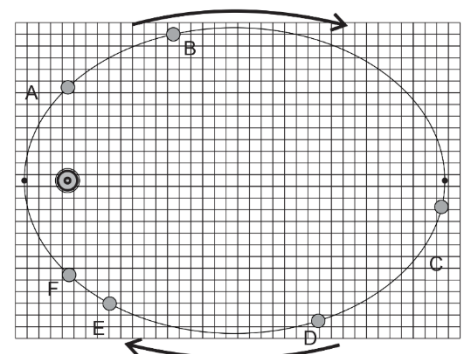

12. The planet spends the same amount of time traveling from point A to point B as it does traveling from _____
 B to C C to D D to E
 E to F F to A

II. Problems (4pts each): For at least one of the problems, you will need at least one bit of this information. For partial credit, show your work. Box your starting formula(s) and your final answer. All answers must include correct units.

$$1.00 \text{ AU} = 1.50 \times 10^{11} \text{ m}$$

$$1.00 \text{ y} = 3.16 \times 10^7 \text{ s}$$

$$M_{\text{Sun}} = 1.99 \times 10^{30} \text{ kg}$$

$$M_{\text{Earth}} = 5.97 \times 10^{24} \text{ kg}$$

$$M_{\text{Moon}} = 7.35 \times 10^{22} \text{ kg}$$

$$R_{\text{Earth}} = 6.378 \times 10^6 \text{ m}$$

- A 0.058kg tennis ball on a string travels in a horizontal circle at a constant speed of 6.30 m/s. If the string is 1.15 m long, what is the tension in the string? [Assume that this happens in a gravity-free environment.]
- The radii of the spheres on the right are 0.1m and 0.15m, respectively. What is the force of gravitational attraction between the two spheres?
- A 1,500kg car traverses a loop-the-loop with a radius of 5m, maintaining a constant speed the whole time. If, at the top of the loop, the car is being pushed downward by a normal force of 5,000N, what is the car's speed?
- A 60kg student is on a ride called the *Ring of Fire*, which travels in vertical circles. At the bottom of one of the circles, the student is traveling at a speed of 11 m/s. Furthermore, the bathroom scale that is supporting her suggests that her weight is three times its normal value. Assuming that her speed is constant, what is the radius of the circle in which the student is traveling?
- An asteroid traveling in a circular orbit circles the Sun once every 4.20 Earth years.
 - What is the radius of the asteroid's orbit in AU (1AU = 1 astronomical unit = Earth's orbital radius)?
 - What is the asteroid's speed, in AU per year (much easier than m/s, in this case)

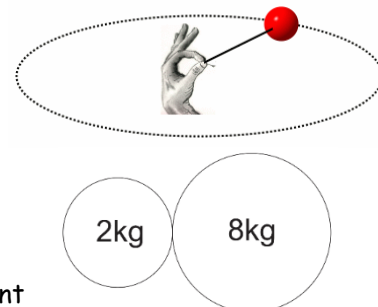

Work and Energy

I. MULTIPLE CHOICE - Assume $g = 10 \text{ m/s}^2$ for the multiple choice questions.

- A greased pig has a choice of three frictionless slides along which to slide to the ground. On which slide will the pig have the greatest velocity at the bottom.
 - Slide A
 - Slide B
 - Slide C
 - The pig's velocity will be the same at the bottom of all three slides.

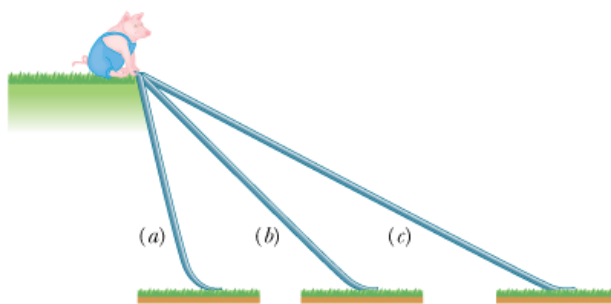

- A man pulls a sled along a rough horizontal surface by applying a constant force F at an angle θ above the horizontal. In pulling the sled a horizontal distance d , the work done by the man is:
 - Fd
 - $Fd \cos \theta$
 - $Fd \sin \theta$
 - $Fd/\cos \theta$
 - $Fd/\sin \theta$
- Power is
 - joules per second.
 - work per unit of time.
 - the rate at which work is done.
 - all of the above.

4. The amount of work (done by an external force) required to stop a moving object is equal to the:
- A. velocity of the object.
 - B. mass of the object times its acceleration.
 - C. kinetic energy of the object.
 - D. mass of the object times its velocity.
 - E. square of the velocity of the object.
7. A 2.0 kg ball is raised to a height of 3.0 m above the ground and then released. (Assume that $U = 0$ at ground level.) After the ball hits the ground, bounces a few times and then comes to rest, which statement is true? [$U=PE$, $K=KE$, and $OE=$ Other Energy]
- A. $U = 0$ J, $K = 0$ J and $OE = 0$ J
 - B. $U = 60$ J, $K = 0$ J and $OE = 60$ J
 - C. $U = 0$, $K = 0$ and $OE = 60$ J
 - D. $U = 0$ J, $K = 60$ J and $OE = 0$
8. [Same conventions as #7]. A simple pendulum with a string length of 0.60 m and a mass of 2.0 kg swings back and forth. At the lowest point in the swing,
- A. U is a maximum and K is a minimum.
 - B. U is a minimum and K is a minimum.
 - C. U is a maximum and K is a maximum.
 - D. U is a minimum and K is a maximum.
9. The potential energy of a box on a shelf, relative to the floor, is a measure of
- A. the work done putting the box on the shelf from the floor.
 - B. the weight of the box times the distance above the floor.
 - C. the energy the box has because of its position above the floor.
 - D. all of these.
10. What does the area under a force versus position (F vs. x) graph represent?
- A. work
 - B. kinetic energy
 - C. power
 - D. potential energy
11. A truck weighs twice as much as a car, and is moving at twice the speed of the car. Which statement is true about the truck's kinetic energy compared to that of the car?
- A. All that can be said is that the truck has more kinetic energy.
 - B. The truck has 8 times the kinetic energy of the car.
 - C. The truck has 4 times the kinetic energy of the car.
 - D. The truck has twice the kinetic energy of the car.
12. A body of mass 2.0 kg is launched upwards with a velocity 20 m/s. It momentarily comes to rest after attaining a height of 18 m. How much energy is lost due to air friction?
- A. 20 J
 - B. 40 J
 - C. 60 J
 - D. 80 J
13. A planet of constant mass orbits the Sun in an elliptical orbit. What happens to the planet's kinetic energy?
- A. It remains constant.
 - B. It increases continually.
 - C. It decreases continually.
 - D. It increases when the planet approaches the Sun, and decreases when it moves farther away.
14. An acorn falls from a tree. What can be said about the acorn's kinetic energy K and its potential energy U ?
- A. K increases and U decreases.
 - B. K decreases and U decreases.
 - C. K increases and U increases.
 - D. K decreases and U increases.

15. A 8000-N car is traveling at 10 m/s along a horizontal road when the brakes are applied. The car skids to a stop in 4.0 s. How much kinetic energy does the car lose in this time?
- A. 5.0×10^3 J C. 4.0×10^4 J E. 8.0×10^5 J
 B. 6.0×10^6 J D. 2.0×10^5 J
16. A 3-kg object is moving at 9 m/s. A 4-N force is applied in the direction of motion and then removed after the object has traveled an additional 5 m. The work done by this force is:
- A. 20 J C. 15 J E. 27 J
 B. 18 J D. 12 J

II. PROBLEMS - For full credit, your starting equation(s) must be clearly shown before substituting in numbers. Circle your answer and have the correct number of significant figures. Assume $g = 9.80$ m/s² for these problems. All work must be done on a separate sheet of paper.

1. Roller Coaster

At the top of the roller coaster ($h = 50.0$ m), $v_i = 10.00$ m/s. Find the velocity of the roller coaster when $h = 15.0$ m.



2. Find the velocity of a 1.50-kg the pendulum at its lowest point in the swing given a difference of 0.220 m between the highest point and the lowest point of the swing.

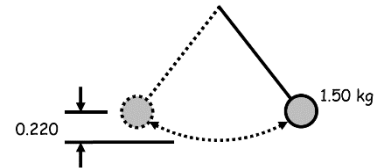

3. A 4.50×10^5 -kg subway train is brought to a stop from a speed of 0.500 m/s in 0.660 m by a large spring bumper at the end of its track. What is the force constant k of the spring?

7. Starting at rest, a 5.00-kg block slides 7.00 m down a frictionless ramp. The ramp makes a 30.0° angle with the horizontal. The block then slides along a horizontal frictionless surface until it strikes a spring with a spring constant $k = 3250$ N/m attached to a rigid wall.

- A. What is the speed of the block on the horizontal surface?
 B. After the block strikes the spring, how far the spring is compressed from its equilibrium position at maximum compression?

